

BRAVAT COMMERCIAL AUTOMATIC CHROME FINISH DECK MOUNTED MOTION SENSOR FAUCET SPECS

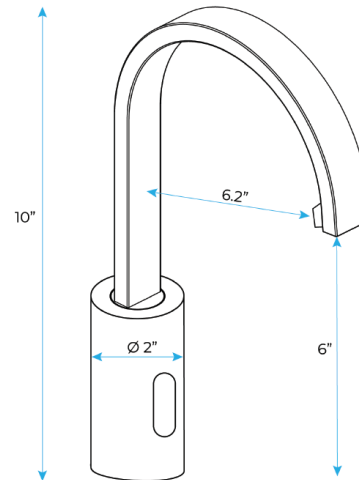

Specs:

- Power: DC:6V(4AA alkaline battery)
- AC:220V-240V; 50/60HZ
- Water Consumption: 0.05Mpa-0.6Mpa
- Detection Zone: 16-32 cm or adjustable
- Motor valve lifespan: up to 500000 flushes
- Usage: Commercial / Residential
- Static Power Consumption: 0.36mw
- Working Power consumption: 0.5mw
- Inductive Opening Time: < 1 second
- Inductive Closing Time: < 2 second
- Dia.of inlet / outlet pipe: G1/2"
- Temperature: 0.1-50°C

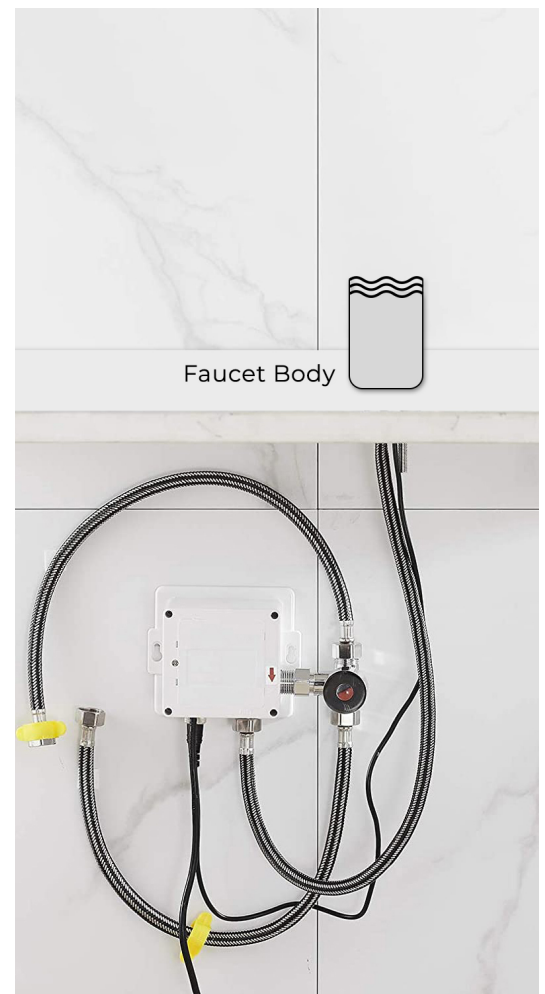

[Visit Product Page](#)